

BOMBA NEUMATICA DE DOBLE MEMBRANA

Modelo: XPX4/AAAAA/BNS/BN/BN/0014



PROFLO[™]
PROGRESSIVE PUMP TECHNOLOGY

SISTEMA: PROFLO X SIN LUBRICACIÓN
SIN POSICIÓN INTERMEDIA,
AJUSTABLE PARA MÁXIMA EFICACIA.
INCORPORA SILENCIADOR



Características generales:

Caudal máximo	327 L/min (ver curvas)
Presión máx. aire	8.6 Bar
Aspiración máx. en seco	6,9 metros. (ver curvas)
Paso sólidos	4,8 mm.
Conexión Asp/imp	1"1/2 - 1"1/4 BSP
Conexión toma de aire	3/4"NPT
Peso	21 kgs

Partes en contacto con el fluido:

Cuerpo	Aluminio
Membranas	Buna
Bolas	Buna
Asientos	Buna
Juntas de asientos	No lleva

Partes sin contacto con el fluido:

Bloque central	Aluminio
Válvula de aire	Aluminio

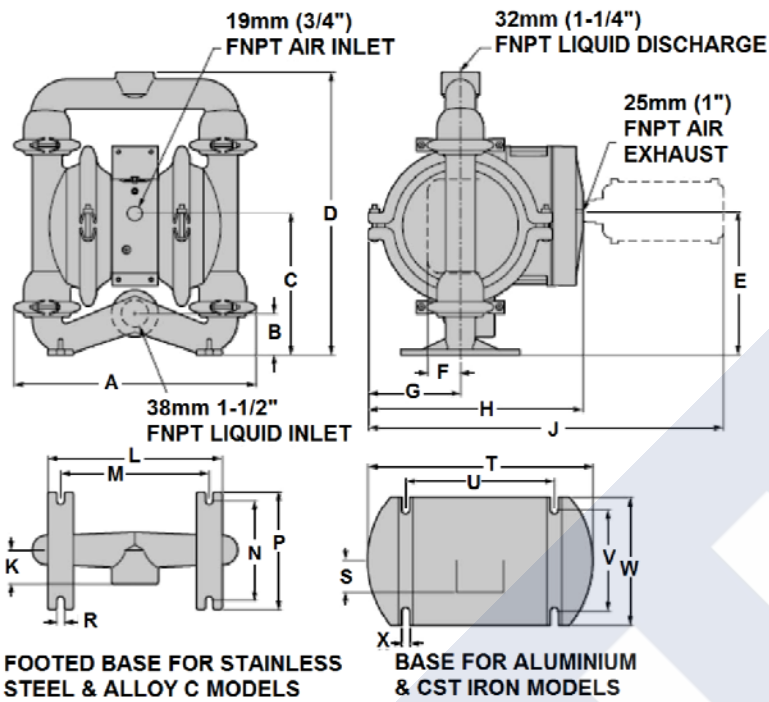

ITEM	METRIC (mm)	STANDARD (inch)
A	368	14.5
B	64	2.5
C	213	0.4
D	429	16.9
E	216	0.5
F	48	1.9
G	147	5.8
H	320	12.6
J	531	20.9
K	51	2.0
L	262	10.3
M	224	0.8
N	150	5.9
P	178	7.0
R	10	0.4
S	48	1.9
T	338	13.3
U	224	0.8
V	155	6.1
W	193	7.6
X	13	0.5

